

NO MORE HEADACHE !

Fast, low cost, high performance,
JOEMARS TR100 BROKEN TAP REMOVER,
your most reliable partner!



Features:

- ❖ **Light, small, portable, and compact design** allows the TR100 tap remover to be moved and used anywhere in the shop.
- ❖ **High speed and efficiency at a low cost.**
- ❖ **Simple set up and operation allows easy removal of taps anywhere.**
- ❖ **Power source choices:** 100V/110V/120V/200V/230V/240V, 1PHASE, 50HZ/60HZ
- ❖ **Dielectric:** Machine uses ordinary tap water as dielectric liquid.
- ❖ **Electrodes:** Uses any brass rod or tube as an electrode.
- ❖ Small size and magnetic base allow machining even on large work pieces.
- ❖ **Removes taps** with no damage or stress to the work piece.
- ❖ **Additional applications** include start holes for wire EDM, and cutting tungsten carbide or any other conductive material.

Machining Functions:

- ❖ **Auto Feed**
- ❖ **Depth setting** (stops at a specific depth)
- ❖ **Selectable arcing timer**
- ❖ **Auto retract**
- ❖ **Swiveling work head**
- ❖ **Alarm messages:** depth arrival, arcing, over-temp.

MACHINING APPLICATIONS:

SMALL WORKPIECE

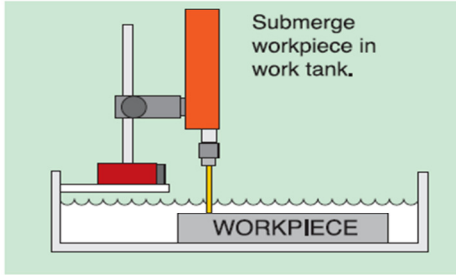

LARGE WORKPIECE

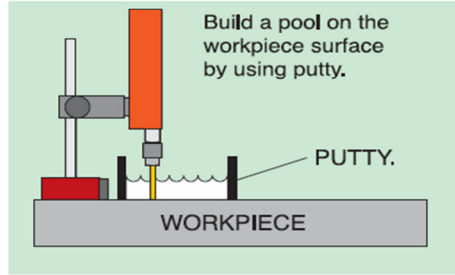

NON-VERTICAL MACHINING

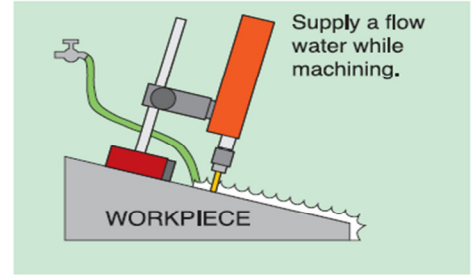

HOW TO REMOVE BROKEN TAP:

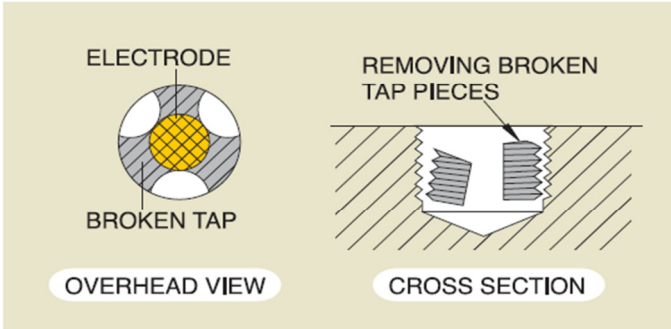

DIMENSIONS:

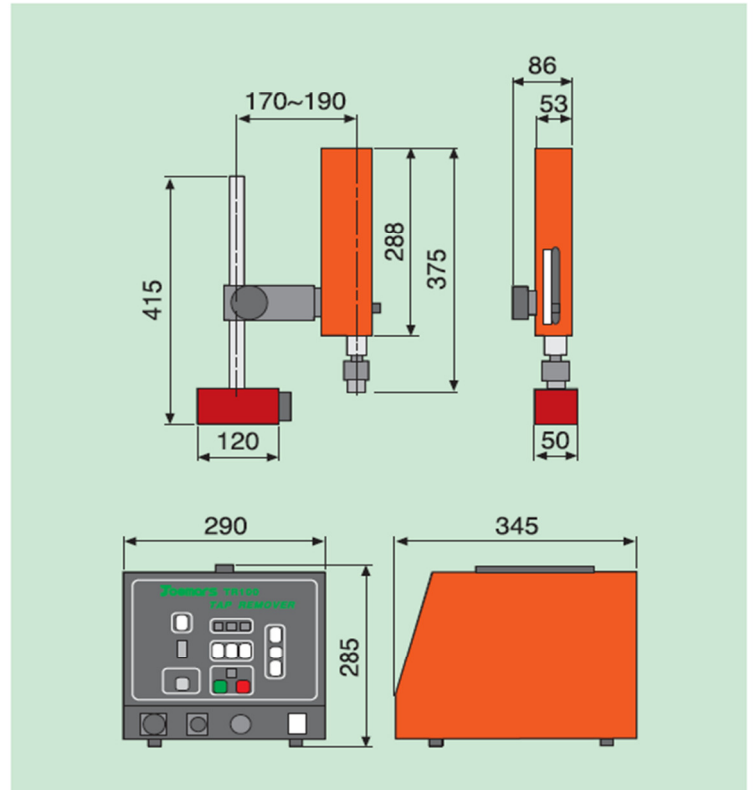

WORKHEAD SWIVEL:

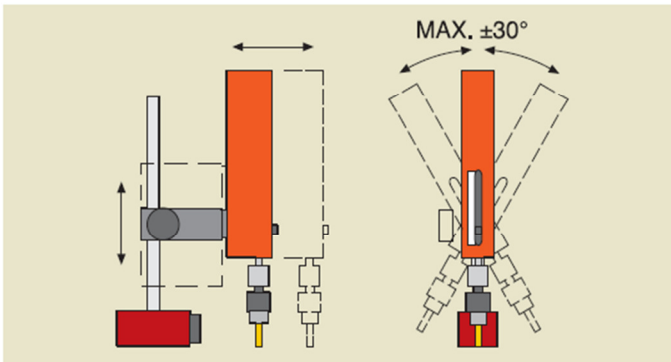

Included Equipment:

1. Generator
2. Machine Unit
3. Chemical Clay
4. Chuck Handle
5. Brass Electrodes
 - 1.5mm x 4PCS
 - 2.0mm x 2PCS
 - 2.5mm x 2PCS
 - 3.0mm x 2PCS
 - 4.0mm x 1PC
 - 5.0mm x 1PC
 - 6.0mm x 1PC

SPECIFICATIONS:

GENERATOR:
Weight: 17Kgs
Dimensions: 290X345X285 mm
MACHINE UNIT:
Weight: 6Kgs with magnetic stand
Dimensions: 53X70X375 mm
Electrode Holder : Max. $\varnothing 6.5$ mm

* All specifications & design are subject to change without notices.